

Step [4] Connecting the Detectors to the DSDIF-C

After you have determined the locations of the Grade Crossing, connect the wires from each detector set to the appropriate DSDIF-C terminals on the left side of the **DSDIF-C** board marked **B W Y R1 R2**. There are four wires for each detector set Red, White, and Black for the receiver, and Yellow and White for the emitter. Connect the white wires from the emitter and receiver together. Connect a length of wire from these white wires to the terminal for the detectors marked **W**. Connect a wire from the yellow wire on the emitter to the terminal marked **Y** of the Detector terminals. Attach a wire to the red wire on the receiver and connect it to the detector terminals **R1**. Repeat these connects for the detector set at the other end of the Grade Crossing Block. Connect the second detector set's red wire to **R2**. See **Figure 5** for details.

Figure 5

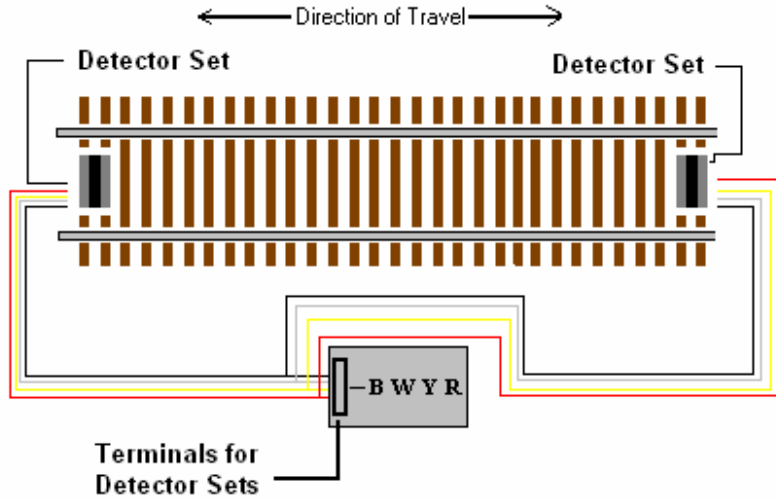

Connect each **DSDIF-C** to the power supply using pieces of wire connected to the + and – terminals on the card to the power supply. The power to the DSDIF-C should be 12volt-18 DC unregulated either from a transformer connected to the house supply or a 12 volt battery. **DO NOT CONNECT THE RELAY CARD TO THE TRACK POWER. Doing so may damage the Relay Card. SBSC will not be responsible for incorrectly powering the Relay Cards with an inappropriate power source.** Connect the power supply to you power source. Check to see if the detected light goes on when each of the detectors in a block are covered. When the red light is on the detectors are working properly.

Multiple Track Applications

If the grade crossing signals protect more than one track, you will need to add additional detector set for the other track. Install the detector set as in step [4] above. Connect the detectors to the board in the same way. See Figure 5 A below.

Figure 5A

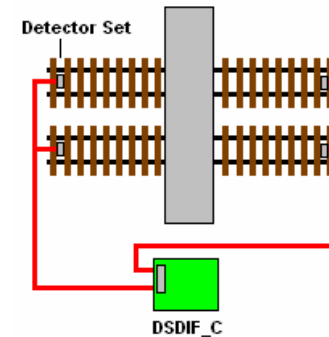

Step [5] Connecting Signals to the DSDIF-C

Follow the instructions supplied with the signals to properly install the signals. Run wire from the crossing signals to the relay cabinet. Connect each color wire from the crossing signal to its appropriate terminal on the Relay Card marked **G Y R**; one signal for the left terminals and one for the right terminals. **The Y terminal is the common lead to the signal.**

Figure 6

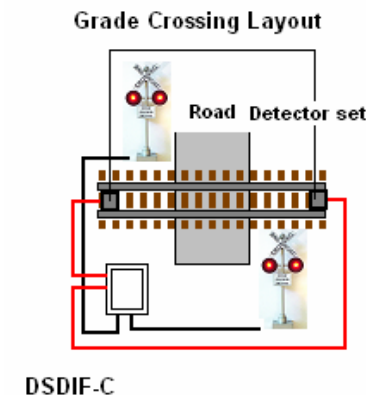

Step [1] Establishing a Grade Crossing Block

The first step if installation is to establish a grade crossing block. A grade crossing block is a section of track that protects a grade crossing at the intersection of a road and tracks which are protected by signals. Figure 1 below illustrated this.

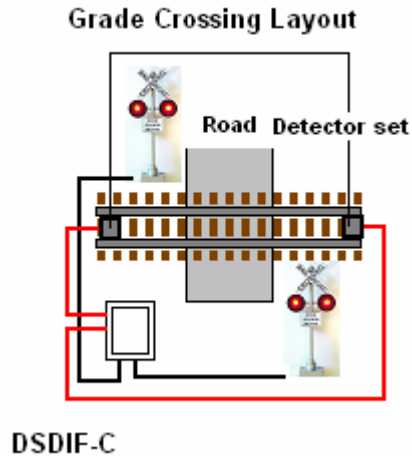

The detector sets are positioned between the rails where the signals are activated to allow enough warning that a train is approaching. There is one detector set at each end of the grade crossing block. See Figure 2.

Figure 2

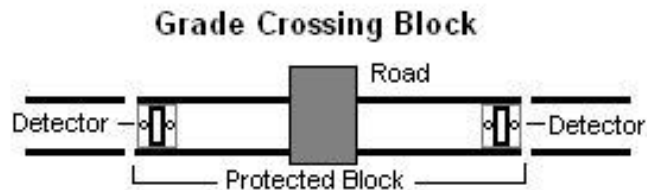

Detector Set Description

Each **DSDIF-C** comes with 2 detector sets. A set consists of an **Emitter** and a **Receiver**. When the signal system is connected to 12-18 volts, the emitter sends out an infrared beam at particular frequency and wave length. The receiver is calibrated to this same frequency and wave length. When the detector set is covered by a locomotive or any piece of rolling stock, the beam from the emitter is bounced off the rolling stock and is recognized by the receiver causing the receiver to transmit a signal to the DSDIF-C's microcontroller that a detection has been made. The microcontroller then turns the crossing signals on.

The emitter has a **YELLOW** and **WHITE** wire connected to it. The **Receiver** has **RED**, **WHITE**, and **BLACK** wires connected to it. The **WHITE** wires of the emitter and **receiver must be connected together with additional wire to a length that will reach the relay board from their positions on the layout.**

Figure 8 below shows how they look.

Figure 8

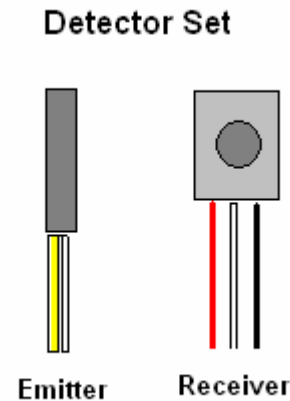

Table of Contents

<u>Description</u>	<u>Page</u>	<u>Notes</u>
DSDIF-C Description and Materials needed	2	
DSDIF-C Terminal Description	3	
Establishing Crossing Signal Blocks	4	
Mounting Detectors Sets	5	
Connecting Detector et to the DSDIF-C	6	
Connecting Signals to the DSDIF-C	7	
Multiple Track Applications	8	
Testing the Signal System	8	
Detector Set Description	9	
Connecting SBSC Crossing Bell (optional)	10	
Notes	11	

Description

The DSDIF-C is a detector/signal driver providing detection and signaling for grade crossing signals.

Specifications

- 12 -18volt DC operation (unregulated)
- 100 ma power draw per board
- Uses infrared state -f-the-art detection device
- Bi-directional providing signal control in both directions of travel
- Two detector sets one for each end of the Grade Crossing block
- Compatible with any train control system: DC or DCC

Materials Needed

- small Phillips and slotted screw driver
- 1/8^{32nd} and 1/4th drill bits and power drill
- 12-18volt DC power source (**not the throttle supply**)
- Wires cutters and wire strippers
- Appropriate hook-up wire